

PTFE Teflon Hoses With Stainless Steel Overbraid



B-Flex Smoothbore PTFE Lined SS Braided Hose Assemblies (1/8" to 1" ID)

- Durable Chemical Hose with Longer Life Cycle



ST-Flex Smoothbore PTFE Lined SS Braided Hose with Silicone Cover (1/8" to 1" ID)

- For Sanitary Applications with Easy to Clean Cover



C-Flex Convoluted PTFE Lined SS Braided Hose Assemblies (3/8" to 4" ID)

- For Applications Needing Additional Flexibility



F-Flex PTFE Lined Fiberglass Braided Hose Assemblies (1/4" to 3/4" ID)

- For Application Needing a Non-Metallic Braid



HP-Flex High Pressure PTFE Lined SS braided Hose Assemblies (1/4" to 1.25" ID)

- For Applications Needing 5,000 PSI Working Pressure

PTFE Teflon Hoses Features and Benefits

General Features and Benefits

- -99°F(-73°C) to 500°F(260°C)
- True I.D Size
- Easily Drains
- Flexible
- Can be sterilized and autoclaved
- High/low pressure rated
- Full vacuum rated
- Thick inner core design
- Working Pressures up to 3,500 P.S.I.
- 4 to 1 safety factor

Stainless Steel Over Braid

- 304 Stainless Steel Braid
- Increases the bending capability of hose
- Protects inner-core from being damaged
- Adds strength to hose
- Protects hose from heat sources and friction

Nominal Hose Sizes, inches

- 1/4" • 1" • 4"
- 3/8" • 1 1/2"
- 1/2" • 2"
- 3/4" • 3"

End Connection Material

- 316 Stainless Steel

Internal Hose Material

- PTFE Teflon®

Smooth Tube PTFE (Inner Core)

- PTFE Teflon® (Dupont T-62)
- Non-Contaminating
- Easy to clean
- Non-aging & Non-stick surface
- Chemically resistant
- Non-absorbent
- No deterioration over time
- Smooth liner- No entrapment issues, reduces build-up of deposits
- Low friction, low pressure drop

Applications

- Instrument Air and Gases
- Paint Sprays
- Steam Transfers
- Oil Supply Lines
- Filling Equipment
- Sanitary Transfers
- Adhesive Conveying

End Connection Types

- Tube Stubs
- Male Pipe Thread
- Female Pipe Thread
- Compression Fitting
- O-Ring Face Seal Fitting
- Metal Gasket Face Seal Fitting
- Female JIC Swivel
- Sanitary Tri-Clamp
- Flange(specify type of Flange)
- Any combination of the above

Overall Length, End to End

- Inches or Centimeters

CONSTRUCTION OF HOSE

SMOOTH PTFE LINER – INNER LAYER

- Polytetrafluoroethylene – PTFE Liner
- Non-absorbent non-stick surface
- Will not impart taste or odor
- Non-Contaminating
- Easy to clean
- Non-aging: no deterioration over time
- Chemical resistance allows for the handling of various fluids
- Reduces entrapment issues
- Reduces build-up of deposits
- Low friction

STAINLESS STEEL BRAID – OUTER LAYER

- Constructed of 304 braided stainless steel
- Strengthens the PTFE hose core
- Increases the bending capability of hose
- Protects the PTFE hose core from damage
- Unique braid reinforcement allows hose to maintain its shape



APPROVALS

Complies with following standards:

- USP Class VI
- FDA 21 CFR177.1550
- USDA
- 3A Sanitary Standards

SAMPLE APPLICATIONS

- Load Cell
- Bulk Transfer
- CIP / SIP Systems
- Filling Equipment
- Steam Transfer
- Fermentation Lines
- Process Lines
- Sanitary Transfer
- Oil Supply Lines
- Sampling Systems
- Paint Sprays
- Feed Lines
- Acid Transfer
- Solvent Transfer
- Mold Press
- Adhesive Conveying

HOSE FITTINGS

- Tubing and connections have identical dimension match
- Hose fittings are 316 stainless steel
- Crimp collars are 304 stainless steel
- Custom hose fittings are available
- Other materials available: hastelloy, inconel, and brass
- Jump size hose fittings are available, which decreases potential leak points
- Electro-Polished fittings available
- Cleaning for oxygen service and other cleaning specs

Western Valve and Fitting Benefits

- 100% Hydrostatically tested
- Cleaned, capped, & individually bagged
- Material & test reports with every order
- All products are labeled for trace-ability
- Commitment to customer service excellence

BENEFITS

- Temperature range from -100°F up to 450°F
- True inner diameter or I.D.
- Full vacuum rated
- Easily drains
- PTFE hose is highly flexible
- Can be sterilized and autoclaved
- Thick or heavy-wall core PTFE hose design

Name	Working Pressure	Burst Pressure	Hose I.D. (Inches)	Hose O.D. (Inches)	Bend Radius (Inches)	Weight (LBS)
B-FLEX-02	3,500 PSI	15,000 PSI	0.125 IN	0.25 IN	1.5 IN	0.05 LBS/FT
B-FLEX-04	3,200 PSI	12,800 PSI	0.25 IN	0.41 IN	1.5 IN	0.10 LBS/FT
B-FLEX-06	2,500 PSI	10,000 PSI	0.375 IN	0.53 IN	2.0 IN	0.12 LBS/FT
B-FLEX-08	2,000 PSI	8,000 PSI	0.50 IN	0.67 IN	3.0 IN	0.16 LBS FT
B-FLEX-12	1,000 PSI	4,500 PSI	0.75 IN	0.87 IN	8.2 IN	0.22 LBS/FT
B-FLEX-16	1,000 PSI	4,000 PSI	1.00 IN	1.19 IN	12.0 IN	0.51 LBS/FT

Note: All hoses shown are also offered with conductive core (BFB)

Part Numbering

Hose Size	Hose Style	Fitting Style	Options	Length
02 (1/8")	BF/BFB	02 Female JIC	AG - Armor Guard	X"
04 (1/4")	BF/BFB	03 Male Pipe NPT	EP - Electro Polished	
06 (3/8")	BF/BFB	06 Female Pipe NPT	FS - Fire Sleeve	
08 (1/2")	BF/BFB	07 Female NPT Union	FT - Flex Tag	
12 (3/4")	BF/BFB	08 Male NPT Union	MT - Mylar Tag	
16 (1")	BF/BFB	10 Sanitary Tri-Clover	OC - Oxygen Cleaned	
		11 Mini Sanitary Tri-Clover	SG - Spiral Guard	
		12 Flange #150 or #300	SPG - Spring Guard	
		31 Male Compression		
		32 Tube Adaptor		
		34 Female Face Seal		

Example of Part Number: 04BF0332MT-12"

04	BF	03	32	MT	-12"
Hose Size	Hose Style	Hose Fitting 1	Hose Fitting 2	Option	Length

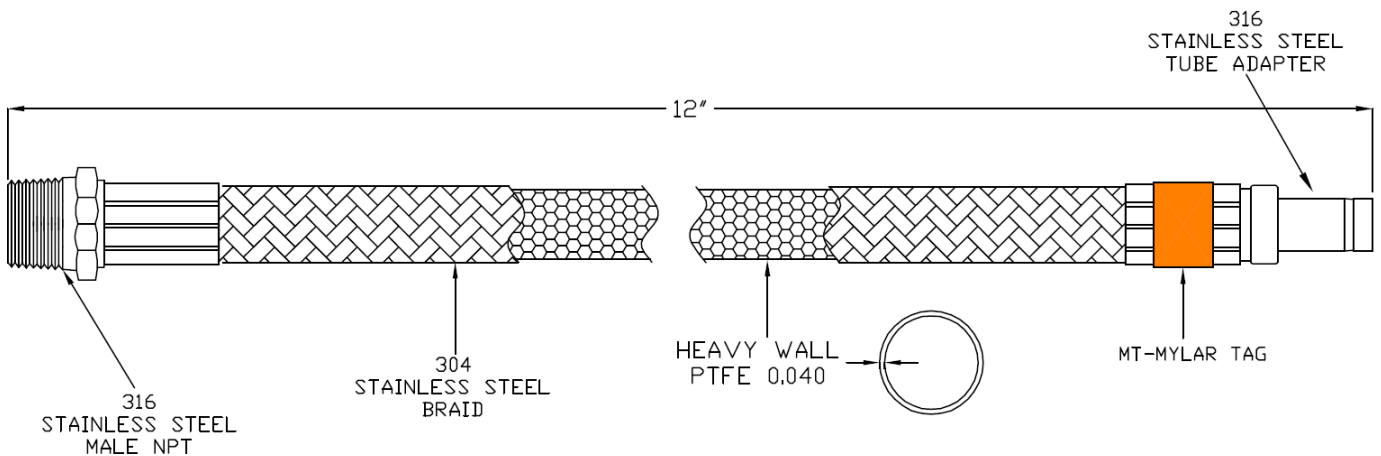

CONSTRUCTION OF HOSE

SMOOTH PTFE LINER – INNER LAYER

- Polytetrafluoroethylene - PTFE Liner
- Non-absorbent non-stick surface
- Will not impart taste or odor
- Non-Contaminating & easy to clean
- Non-aging: no deterioration over time
- Chemical resistance allows for the handling of various fluids
- Reduces entrapment & build-up of deposits
- Low friction

STAINLESS STEEL BRAID

- Constructed of 304 braided stainless steel
- Strengthens the PTFE hose core
- Increases the bending capability of hose
- Protects the PTFE hose core from damage
- Unique braid reinforcement allows hose to maintain its shape

EXTRUDED SILICONE JACKET – OUTER LAYER

- Rated for high temperature
- Smooth, cleanable, non-contaminating surface
- Compatible with a wide variety of chemicals
- Extra protection from hot and cold media transfers through PTFE hose

HOSE FITTINGS

- Tubing and connections have identical dimension match
- Hose fittings are 316 stainless steel
- Crimp collars are 304 stainless steel
- Custom hose fittings are available
- Other materials available: hastelloy, inconel, and brass
- Jump size hose fittings are available, which decreases potential leak points
- Electro-Polished fittings available
- Cleaning for oxygen service and other cleaning specs

- 100% Hydrostatically tested
- Cleaned, capped, & individually bagged
- Material & test report with every order
- All products are labeled for tractability
- Commitment to customer service excellence

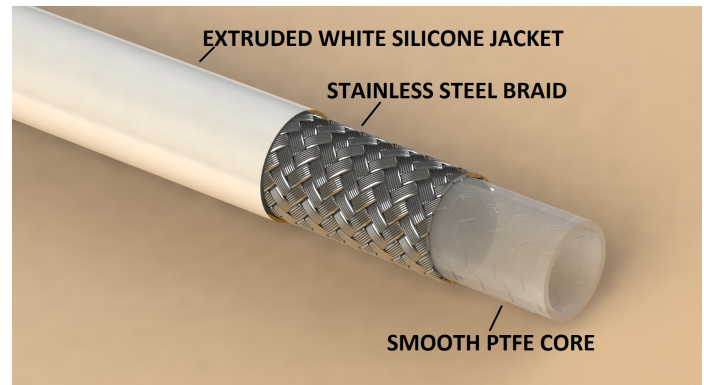

APPROVALS

Complies with following standards:

- USP Class VI
- FDA 21 CFR177.1550
- USDA
- 3A Sanitary Standards

SAMPLE APPLICATIONS

- Load Cell
- Bulk Transfer
- CIP / SIP Systems
- Filling Equipment
- Steam Transfer
- Fermentation Lines
- Process Lines
- Sanitary Transfer
- Oil Supply Lines
- Sampling Systems
- Paint Sprays
- Feed Lines
- Acid Transfer
- Solvent Transfer
- Mold Press
- Adhesive Conveying

BENEFITS

- Temperature range from -100°F 450°F
- True inner diameter or I.D.
- Full vacuum rated
- Easily drains
- PTFE hose is highly flexible
- Can be sterilized and autoclaved
- Thick or heavy-wall core PTFE hose design

Name	Working Pressure	Burst Pressure	Hose I.D. (Inches)	Hose O.D. (Inches)	Bend Radius (Inches)	Weight (LBS)
ST-FLEX-02	3,500 PSI	15,000 PSI	0.125 IN	0.43 IN	1.5 IN	0.11 LBS/FT
ST-FLEX-04	3,250 PSI	13,000 PSI	0.25 IN	0.50 IN	1.5 IN	0.13 LBS/FT
ST-FLEX-06	2,500 PSI	10,000 PSI	0.375 IN	0.65 IN	2.0 IN	0.15 LBS/FT
ST-FLEX-08	2,000 PSI	8,000 PSI	0.50 IN	0.81 IN	3.0 IN	0.18 LBS/FT
ST-FLEX-12	1,000 PSI	4,500 PSI	0.75 IN	1.02 IN	8.2 IN	0.35 LBS/FT
ST-FLEX-16	1,000 PSI	4,000 PSI	1.00 IN	1.36 IN	12.0 IN	0.68 LBS/FT

Note: All hoses shown are also offered with conductive core (STB)
Note: ST-FLEX-16 has a blown on cover and not extruded.

Part Numbering

Hose Size	Hose Style	Fitting Style	Options	Length
02 (1/8")	ST/STB	02 Female JIC	AG - Armor Guard	X"
04 (1/4")	ST/STB	03 Male Pipe NPT	EP - Electro Polished	
06 (3/8")	ST/STB	06 Female Pipe NPT	FS - Fire Sleeve	
08 (1/2")	ST/STB	07 Female NPT Union	FT - Flex Tag	
12 (3/4")	ST/STB	08 Male NPT Union	MT - Mylar Tag	
16 (1")	ST/STB	10 Sanitary Tri-Clover	OC - Oxygen Cleaned	
		11 Mini Sanitary Tri-Clover	SG - Spiral Guard	
		12 Flange #150 or #300	SPG - Spring Guard	
		31 Male Compression		
		32 Tube Adaptor		
		34 Female Face Seal		

Example of Part Number: 04ST1011FT-89"

04	ST	10	11	FT	-89"
Hose Size	Hose Style	Hose Fitting 1	Hose Fitting 2	Option	Length

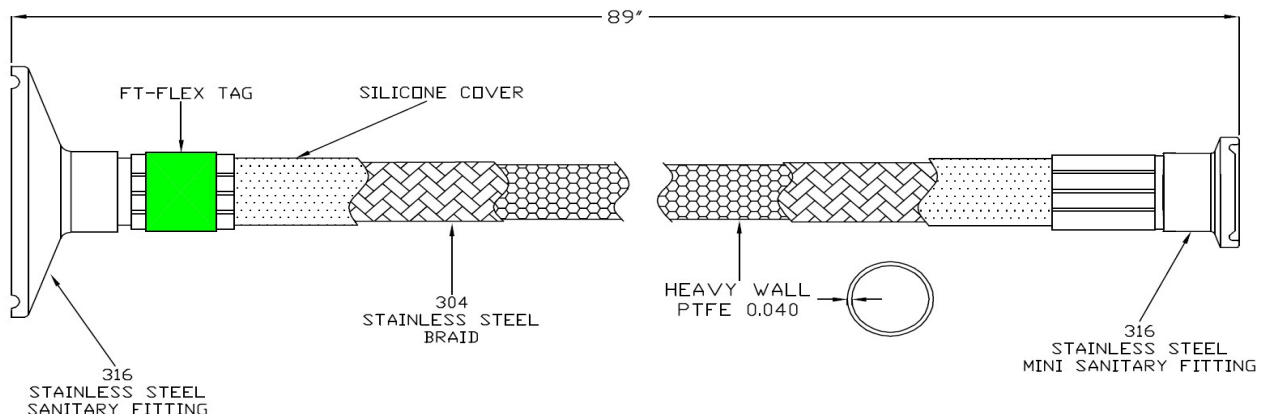

ISO 9001-2015 & ITAR Registered

CAGE CODE: 5F9E3

QUALITY PRODUCTS DELIVERED FASTER

MADE IN USA

CONSTRUCTION OF HOSE

CONVOLUTED PTFE LINER – INNER LAYER

- Polytetrafluoroethylene – PTFE Liner
- Non-absorbent non-stick surface
- Will not impart taste or odor
- Non-Contaminating
- Easy to clean
- Non-aging: no deterioration over time
- Chemical resistance allows for the handling of various fluids
- Reduces entrapment & build-up of deposits
- Low friction
- Increased flexibility with convoluted liner

STAINLESS STEEL BRAID – OUTER LAYER

- Constructed of 304 braided stainless steel
- Strengthens the PTFE hose core
- Increases the bending capability of hose
- Protects the PTFE hose core from damage
- Unique braid reinforcement allows hose to maintain its shape



HOSE FITTINGS

- Tubing and connections have identical dimension match
- Hose fittings are 316 stainless steel
- Crimp collars are 304 stainless steel
- Custom hose fittings are available
- Other materials available: hastelloy, inconel, and brass
- Jump size hose fittings are available, which decreases potential leak points
- Electro-Polished fittings available
- Cleaning for oxygen service and other cleaning specs

Western Valve and Fitting Benefits

- 100% Hydrostatically tested
- Cleaned, capped, & individually bagged
- Material & test reports with every order
- All products are labeled for trace-ability
- Commitment to customer service excellence

APPROVALS

Complies with following standards:

- USP Class VI
- FDA 21 CFR177.1550
- USDA
- 3A Sanitary Standards

SAMPLE APPLICATIONS

- Load Cell
- Bulk Transfer
- CIP / SIP Systems
- Filling Equipment
- Steam Transfer
- Fermentation Lines
- Process Lines
- Sanitary Transfer
- Oil Supply Lines
- Sampling Systems
- Paint Spray
- Feed Lines
- Acid Transfer
- Solvent Transfer
- Mold Press
- Adhesive Conveying

BENEFITS

- Temperature range from -100°F up to 450°F
- True inner diameter or I.D.
- Vacuum rated
- Convoluted PTFE is highly flexible in larger sizes where smoothbore cannot be used
- Can be sterilized and autoclaved
- Drainable helical PTFE core design

Name	Working Pressure	Burst Pressure	Hose I.D. (Inches)	Hose O.D. (Inches)	Bend Radius (Inches)	Weight (LBS)
C-FLEX-08	1,500 PSI	6,000 PSI	0.50 IN	0.76 IN	2.5 IN	0.19 LBS/FT
C-FLEX-12	1,100 PSI	4,400 PSI	0.75 IN	1.00 IN	3.0 IN	0.27 LBS/FT
C-FLEX-16	1,000 PSI	4,000 PSI	1.00 IN	1.32 IN	5.5 IN	0.39 LBS/FT
C-FLEX-24	700 PSI	2,800 PSI	1.50 IN	2.03 IN	6.0 IN	0.75 LBS/FT
C-FLEX-32	525 PSI	2,100 PSI	2.00 IN	2.46 IN	7.5 IN	0.89 LBS/FT

Note: All hoses shown are also offered with conductive core (CFB)

Part Numbering

Hose Size	Hose Style	Fittings Style	Options	Length
08 (1/2")	CF/CFB	02 Female JIC	AG - Armor Guard	X"
12 (3/4")	CF/CFB	03 Male Pipe NPT	EP - Electro Polished	
16 (1")	CF/CFB	06 Female Pipe NPT	FS - Fire Sleeve	
24 (1.5")	CF/CFB	07 Female NPT Union	FT - Flex Tag	
32 (2")	CF/CFB	08 Male NPT Union	MT - Mylar Tag	
		10 Sanitary Tri-Clover	OC - Oxygen Cleaned	
		11 Mini Sanitary Tri-Clover	SG - Spiral Guard	
		12 Flange #150 or #300	SPG - Spring Guard	
		31 Male Compression		
		32 Tube Adaptor		
		34 Female Face Seal		

Example of Part Number: 12CF0212#150MT-240"

12	CF	02	12	MT	-240"
Hose Size	Hose Style	Hose Fitting 1	Hose Fitting 2	Option	Length

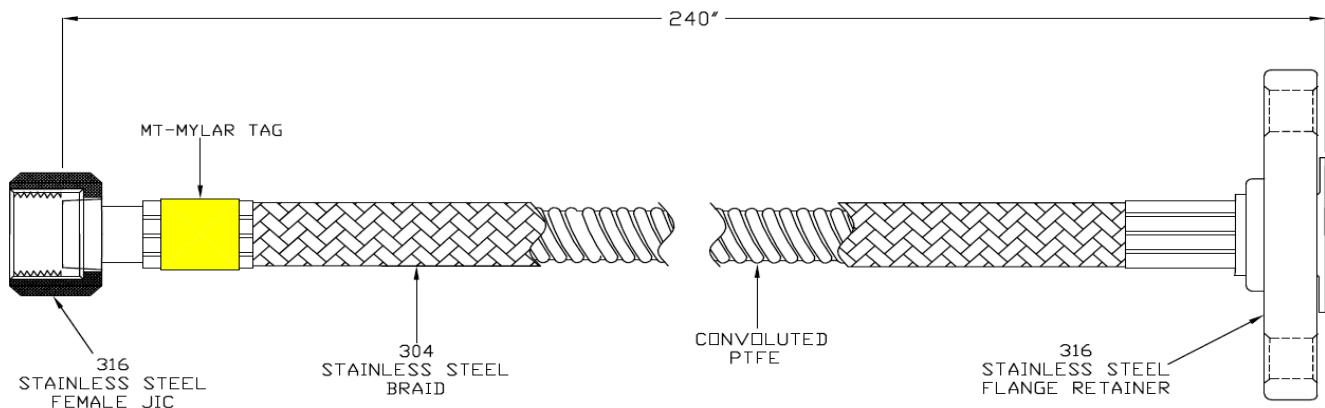

CONSTRUCTION OF HOSE

SMOOTH PTFE LINER – INNER LAYER

- Polytetrafluoroethylene – PTFE Liner
- Non-absorbent non-stick surface
- Will not impart taste or odor
- Non-Contaminating
- Easy to clean
- Non-aging: no deterioration over time
- Chemical resistance allows for the handling of various fluids
- Reduces entrapment issues
- Reduces build-up of deposits
- Low friction

FIBERGLASS BRAID – OUTER LAYER

- Non-Metallic braid
- Increased Insulation



APPROVALS

Meets or exceeds the following standards:

- USP Class VI
- FDA 21 CFR177.1550
- USDA
- 3A Sanitary Standards
- NSF 51

SAMPLE APPLICATIONS

- Load Cell
- Bulk Transfer
- CIP / SIP Systems
- Filling Equipment
- Steam Transfer
- Fermentation Lines
- Process Lines
- Sanitary Transfer
- Oil Supply Lines
- Sampling Systems
- Paint Sprays
- Feed Lines
- Acid Transfer
- Solvent Transfer
- Mold Press
- Adhesive Conveying

HOSE FITTINGS

- Tubing and connections have identical dimension match
- Hose fittings are 316 stainless steel
- Crimp collars are 304 stainless steel
- Custom hose fittings are available
- Other materials available: hastelloy, inconel, and brass
- Jump size hose fittings are available, which decreases potential leak points
- Electro-Polished fittings available
- Cleaning for oxygen service and other cleaning specs

Western Valve and Fitting Benefits

- 100% Hydrostatically tested
- Cleaned, capped, & individually bagged
- Material & test reports with every order
- All products are labeled for trace-ability
- Commitment to customer service excellence

BENEFITS

- Temperature range from -100°F up to 450°F
- True inner diameter or I.D.
- Full vacuum rated
- Easily drains
- PTFE hose is highly flexible
- Can be sterilized and autoclaved
- Thick or heavy-wall core PTFE hose design

Name	Working Pressure	Burst Pressure	Hose I.D. (Inches)	Hose O.D. (Inches)	Bend Radius (Inches)	Weight (LBS)
F-FLEX-04	800 PSI	3,200 PSI	0.250 IN	0.415 IN	2.75 IN	0.07 LBS/FT
F-FLEX-06	800 PSI	2,600 PSI	0.375 IN	0.550 IN	3.25 IN	0.10 LBS/FT
F-FLEX-08	450 PSI	1,800 PSI	0.500 IN	0.710 IN	5.25 IN	0.13 LBS/FT
F-FLEX-12	325 PSI	1,300 PSI	0.750 IN	0.945 IN	6.50 IN	0.20 LBS/FT

Note: All hoses shown are also offered with conductive core (FFB)

Part Numbering

Hose Size	Hose Style	Fitting Style	Options	Length
04 (1/4")	FF/FFB	02 Female JIC	AG - Armor Guard	X"
06 (3/8")	FF/FFB	03 Male Pipe NPT	EP - Electro Polished	
08 (1/2")	FF/FFB	06 Female Pipe NPT	FS - Fire Sleeve	
12 (3/4")	FF/FFB	07 Female NPT Union	FT - Flex Tag	
16 (1")	FF/FFB	08 Male NPT Union	MT - Mylar Tag	
	FF/FFB	10 Sanitary Tri-Clover	OC - Oxygen Cleaned	
		11 Mini Sanitary Tri-Clover	SG - Spiral Guard	
		12 Flange #150 or #300	SPG - Spring Guard	
		31 Male Compression		
		32 Tube Adaptor		
		34 Female Face Seal		

Example of Part Number: 04FF0332MT-12"

04	FF	03	32	MT	-12"
Hose Size	Hose Style	Hose Fitting 1	Hose Fitting 2	Option	Length

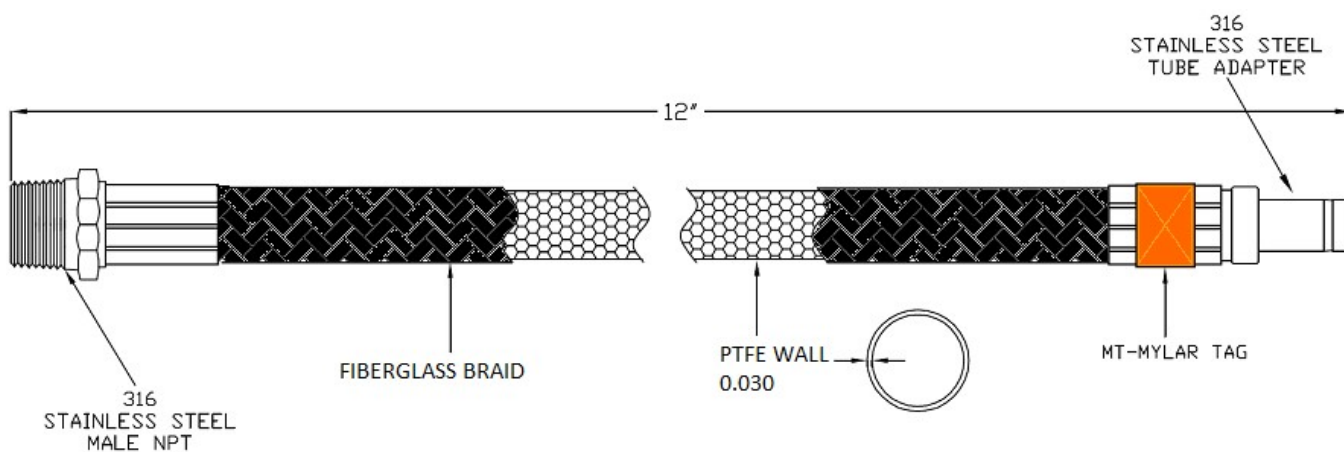

HP-FLEX High Pressure PTFE Hose



Constructed with a smooth bore PTFE liner that is impregnated with carbon black, which provides conductivity for static dissipation and a longer life for the assembly. The outer reinforcement is a unique bunch braid design made of 300 series stainless steel.

ADVANTAGES

- Conductive PTFE tube results longer hose assembly life
- Excellent chemical resistance
- Broad operating temperature range
- Rust and corrosion resistant

HP-Flex Hose Specifications							
Name	Name	Working Pressure	Burst Pressure	Hose I.D. (Inches/ MM)	Hose O.D. (Inches/ MM)	Bend Radius (Inches/ MM)	Weight
HP-FLEX-04-GAS	HP-FLEX-04-LIQ	5,000 PSI	16,000 PSI	0.22 IN / 5.58 MM	0.37 IN / 9.39 MM	1.5 IN / 38.1 MM	0.108 LBS/FT
HP-FLEX-06-GAS	HP-FLEX-06-LIQ	5,000 PSI	16,000 PSI	0.30 IN / 7.62 MM	0.47 IN / 11.93 MM	2.5 IN / 63.5 MM	0.180 LBS/FT
HP-FLEX-08-GAS	HP-FLEX-08-LIQ	5,000 PSI	16,000 PSI	0.40 IN / 10.16 MM	0.60 IN / 15.24 MM	2.9 IN / 73.66 MM	0.240 LBS/FT
HP-FLEX-10-GAS	HP-FLEX-10-LIQ	5,000 PSI	16,000 PSI	0.49 IN / 12.44 MM	0.71 IN / 18.03 MM	3.3 IN / 83.82 MM	0.324 LBS/FT
HP-FLEX-12-GAS	HP-FLEX-12-LIQ	5,000 PSI	16,000 PSI	0.61 IN / 15.49 MM	0.97 IN / 24.63 MM	4.0 IN / 101.6 MM	0.660 LBS/FT
HP-FLEX-16-GAS	HP-FLEX-16-LIQ	5,000 PSI	16,000 PSI	0.86 IN / 21.84 MM	1.25 IN / 31.75 MM	5.0 IN / 127 MM	1.020 LBS/FT
HP-FLEX-20-GAS	HP-FLEX-20-LIQ	4,000 PSI	16,000 PSI	1.12 IN / 28.44 MM	1.60 IN / 40.64 MM	12.0 IN / 304.8 MM	1.680 LBS/FT
HP-FLEX-24-GAS	HP-FLEX-24-LIQ	4,000 PSI	12,000 PSI	1.37 IN / 34.79 MM	1.92 IN / 48.76 MM	14.0 IN / 355.6 MM	2.280 LBS/FT

High Pressure Smooth Bore Hose



**Operating pressures shown are for non-impulsive service. Reduce operating pressures by 1000psi for pump discharge and similar impulse service applications. For service at 400° F, maximum operating pressure for all sizes is 3000 psi.*

HP-Flex-xx-Gas hose constructed with a post-sintered core for low effusion levels – for industrial gas and impulse applications.